

THIS DRAWING IS UNPUBLISHED. RELEASED FOR PUBLICATION, 19 .
 © COPYRIGHT 19 BY AMP INCORPORATED. ALL INTERNATIONAL RIGHTS RESERVED.

LOC	DIST	P	F	ZONE	LTR	REVISIONS	DATE	APPD
AF	50				E	REDRAWN PER 0710-0014-96	1/26/96	JR/JH

- 1 CONTINUOUS STRIP ON REELS.
- 2 MATING TAB THK TO BE 0.813±0.025 [.032±.001].
- 3 ACCEPTS WIRE SIZES [#22-#18] AWG.
- 4 INSULATION RANGE TO BE 2.29-3.30 [.090-.130] DIA.

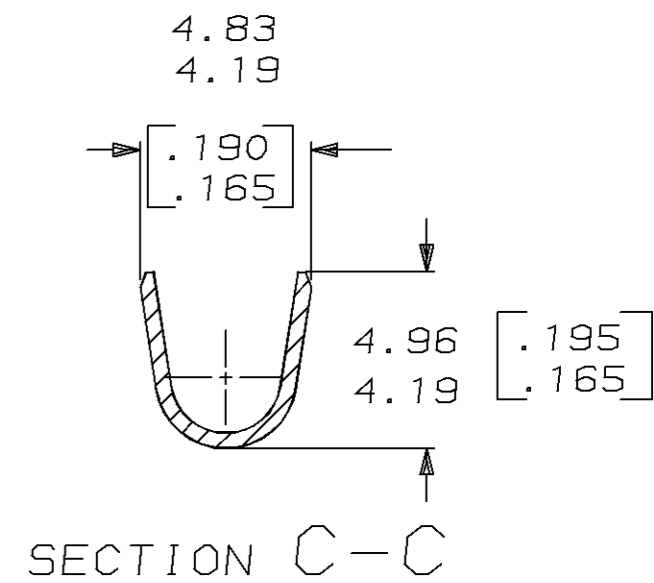
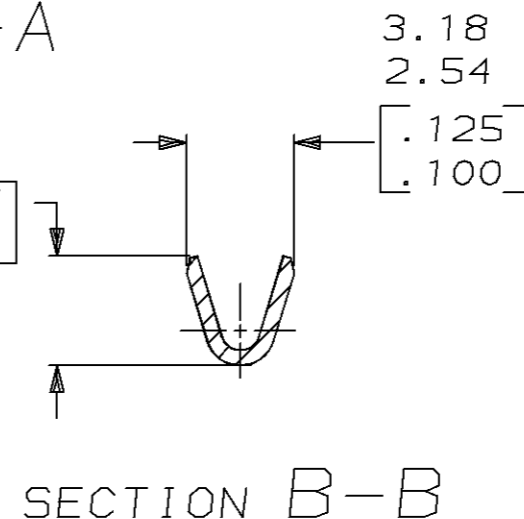
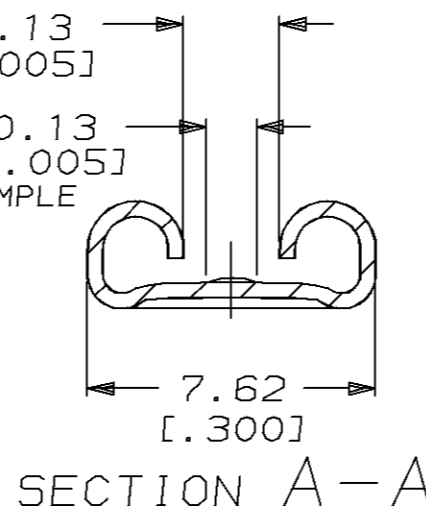
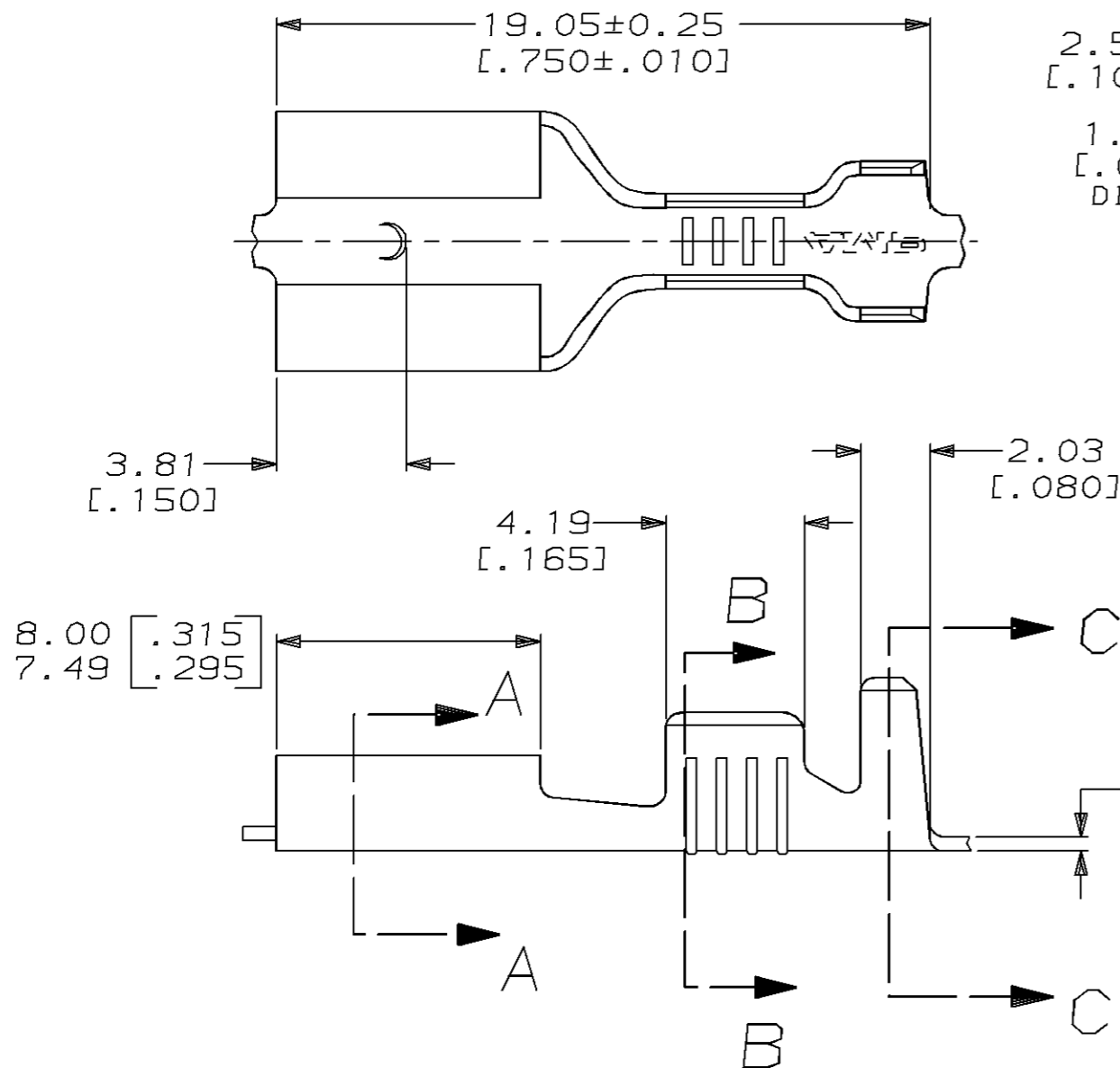

THIS DRAWING IS A CONTROLLED DOCUMENT FOR AMP INCORPORATED. IT IS SUBJECT TO CHANGE AND THE CONTROLLING ENGINEERING ORGANIZATION SHOULD BE CONTACTED FOR THE LATEST REVISION.

63127-1
PART NO

DO NOT SCALE PRINT. UNLESS SPECIFIED DIMENSIONS IN mm [INCHES] TOLERANCES ON: 2 PLC DEC ± 0.38 [.015] 3 PLC DEC ± - ANGLES ± -		DR 1/26/96 JR RUTH	AMP AMP Incorporated Harrisburg, PA 17105-3608
MATERIAL H04 BRASS		CHK 1/26/96 MS FEHER	
FINISH -		APPD 1/26/96 J HUZVAR	NAME RECEPTACLE, FASTON, 6.35 [.250] SERIES
		APPD 1/26/96 V KARABCIEVSKY	SIZE B
		PRODUCT SPEC -	CAGE CODE 00779
		APPLICATION SPEC -	DRAWING NO C-63127
		WEIGHT -	SCALE 5:1
			SHEET 1 OF 1

CUSTOMER DRAWING